

# Owner's Manual

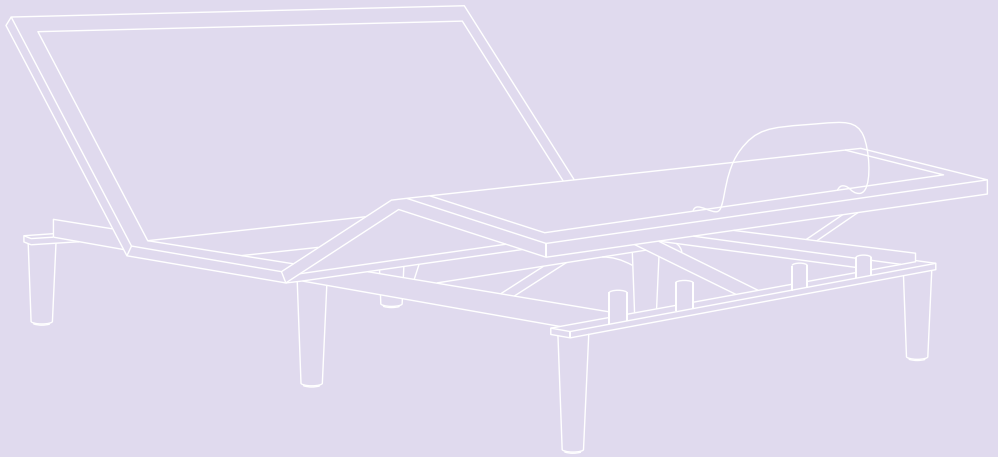

---

## TABLE OF CONTENTS

Safety Precautions and Usage Statements . . . . .	03
Parts List . . . . .	07
Base and Remote Overview . . . . .	10
Quick Reference Guide . . . . .	13
Installation Guide . . . . .	15
King Installation Guide . . . . .	19
Remote Control . . . . .	25
Pairing the Remote . . . . .	27
Connecting Strap . . . . .	29
Syncing Two Bases . . . . .	30
Headboard Brackets. . . . .	31
Emergency Battery Backup Strap . . . . .	33
Troubleshooting . . . . .	35
Notes. . . . .	36
Purple® 10 Year Limited Warranty . . . . .	38

# Safety Precautions and Usage Statements

## ATTENTION: IMPORTANT SAFETY DISCLAIMERS

Read the following information before using this product. Failure to use a surge protection device could compromise safety or cause product malfunction and could void the electrical portion of your warranty.

---

## SAFETY PRECAUTIONS and USAGE STATEMENTS

### TO REDUCE THE RISK OF SHOCK, BURNS, FIRE OR INJURY

For optimal safety and operation, plug bed base into a surge protector (not included). The bed base should only be plugged directly into a wall outlet or surge protector (strongly recommended). Always unplug the base from the electrical outlet before servicing any part of the base. To reduce risk of electric shock, unplug the base before cleaning. To safely disconnect, ensure the base is in a flat position with all motors off, and unplug from power source. Keep the power cord away from heated surfaces. Never operate the base when the air openings are blocked. Keep air openings free of lint, hair, and the like. Do not drop or insert any object into any opening. Discontinue use of the bed base and contact a qualified service center if: it has a damaged cord or plug, it is not working properly, or it has been dropped into water. Only use this bed base for its intended use as described in this manual. Do not use accessories/attachments that are not recommended by the manufacturer. Close supervision is required when the bed base is used by or near children, convalescents, disabled persons, or pets. Improper connection of the equipment can result in the risk of electrical shock, electrical fire, or faulty operation of this bed base. If the plug does not fit your outlet, contact a qualified electrician to install a suitable outlet. Unauthorized modification or failure to use a wall outlet or surge protector could void the electrical portion of your warranty.

### PETS AND CHILDREN

Immediately dispose of all packing materials as it may pose a smothering risk to small children and pets. To avoid injury, it is not advised to allow children and small

pets to play on or under the bed. Children should not operate the bed base without adult supervision.

### PACEMAKERS

Some products contain neodymium magnets which may interfere with devices such as pacemakers, ICDs, and any other device sensitive to magnetic fields. It is **STRONGLY** recommended that owners of such medical devices consult their physician prior to using products that contain neodymium magnets.

### IN-HOME USE AND HOSPITAL STANDARDS

Purple adjustable bed bases are designed solely for in-home use. This base was not designed as a hospital bed and is not designed to meet hospital standards. Do not use this base with tent-type oxygen therapy equipment or near explosive gases.

### ADDITIONAL SAFETY FEATURES

Free release head and foot motors are designed to lower the mattress by retracting only with gravity, never pulling downwards, which minimizes pinch points.

### LIFTING/LOWERING MECHANISMS

The lift/lower feature will emit a minimal humming sound during operation. This is normal. During operation, the lift arm wheels make contact with the platform support of the base. This contact may result in metal on metal or metal on plastic contact. This applies slight tension on the moving components and resonance is reduced to a minimum level. If excessive noise or vibration is experienced, reverse the movement action (up or down) of the base with the remote control. This should realign the base's activating mechanisms to

## SAFETY PRECAUTIONS and USAGE STATEMENTS

the proper operational position. In normal base operation, the wheels, which allow the bed to maintain its distance from the wall, will make contact with the steel platform supports of the base, creating a contact noise. When entering, exiting, or shifting weight on the base, this contact noise may be audible as the wheels make contact. This is normal.

### MATERIALS

Purple adjustable bases are constructed from various materials including woods, metals, plastics and fabrics. Tension, pressure, or movement applied to the frame, platform, or shroud through general use may create an audible sound.

### TOLERANCE

All Purple adjustable foundations, depending on make and model, are designed and manufactured to perform and function within designated quality control parameters. Bases are subject to meticulous and rigorous inspections during the quality control process to ensure bases will operate within these standards during normal operating use. Normal operating use is defined as the following: Adjustable foundation is to be operated with a mattress and load. Testing procedures require lifetime cycle tests with up to 120 kg distributed load. The angle (designated " $\beta$ " in figure 1) between the back section and the flat section for various configurations of the mattress support platform shall be  $\pm 3^\circ$ , which translates to a tolerance of up to  $1\frac{1}{2}^\circ$ . The angle (designated " $\alpha$ " in figure 1) between the flat section and foot section for various configurations of the mattress support platform shall be  $\pm 3^\circ$ , which translates to a tolerance of up to  $\frac{3}{4}^\circ$ . Any adjustable foundation deemed to

be within these allocated tolerances is considered to have met the manufacturer's quality control standards.

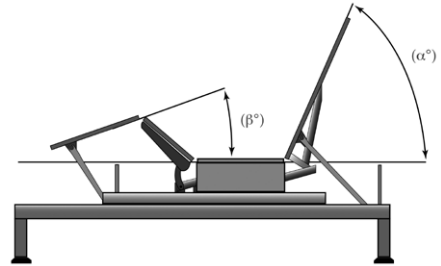

### THAT "NEW PRODUCT" SMELL

Some people notice a slight odor to their new adjustable base – this can come from our material manufacturing process. This smell is normal and usually disappears before the product reaches you. Sometimes, however, this smell may still be noticeable. It usually disappears after a few weeks, providing adequate ventilation of the product and the environment.

### BREAK IN PERIOD

You can speed up the break-in period by simply using the head/foot adjustment features of the bed for activities such as reading or watching TV. The extra movement will help the adjustable base respond to weight and temperature changes. Some of the materials in our adjustable bases such as the woods, metals, and plastics used in the platform, frame, and components are sensitive to moisture content and temperature and may make sounds in colder environments.

### PAIRED OPERATION

When operating a "paired" split base set-up, there may be a time delay of up to 1.5 seconds between each base's articulation.

---

## SAFETY PRECAUTIONS and USAGE STATEMENTS

### WEAR AND TEAR

Wear and tear is damage that naturally and inevitably occurs as a result of normal use or aging.

### FABRIC CARE

To prolong the life of your fabric, protect from direct sunlight whenever possible. For spot cleaning, wipe area with a light damp sponge or vacuum with a soft brush attachment to remove particles. Keep at a minimum of 30 cm (12 inches) away from direct heat sources. For a deeper cleaning, blot liquid spills with a clean dry cloth. Wipe with a clean cloth dampened with warm water. Do not wet excessively. A soft bristle brush may be used to remove ingrained soil. Avoid scratching by gentle brushing. Wipe with a clean cloth dampened with warm water to remove residues. Dry in shade away from direct heat. If persistent marks remain visible after cleaning, seek professional advice.

### PRODUCT RATINGS

The lift motors are not designed to operate continuously for more than two minutes in an 18-minute time period. Attempting to circumvent or exceed this rating will shorten the life expectancy of the product and may void the warranty.

### WEIGHT LIMITS

This product is not rated to support weights in excess of 750 pounds. The base will structurally support this weight, provided it is evenly distributed across the bed base. The adjustable base is not designed to support or lift this amount in the head or foot sections alone. Exceeding this weight restriction could damage the bed and/or cause injury and will void the warranty.

### SAVE THESE INSTRUCTIONS.

#### FCC Compliance

This equipment has been tested and found to comply with the limits for a Class B digital device, pursuant to part 15 of the FCC Rules. These limits are designed to provide reasonable protection against harmful interference in a residential installation. This equipment generates, uses, and can radiate radio frequency energy and, if not installed and used in accordance with the instructions, may cause harmful interference to radio communications. However, there is no guarantee that interference will not occur in a particular installation. If this equipment does cause harmful interference to radio or television reception, which can be determined by turning the equipment off and on, the user is encouraged to try to correct the interference by one or more of the following measures:

- Reorient or relocate the receiving antenna.
- Increase the distance between the equipment and receiver.
- Connect the equipment into an outlet on a circuit different from that to which the receiver is connected.
- Consult the dealer or an experienced radio/TV technician for help.

# Parts List

---

## PARTS LIST

All electronics and components that need to be installed are located in boxes under the base or attached to the frame.

- A Wireless Remote Control (1)
- B Mattress Retainer Bar (1)\*
- C Legs (6)
- D Power Cord (1)
- E Power Supply (1)
- F Sync Cord ‡
- G Battery Backup Strap (1)  
(2) 9V Batteries (not included)
- H Connecting Strap‡

Misc Parts (not included):

- I Surge Protector

Headboard Bracket Components (Optional):

- J Headboard Bracket (2)†
- K T-Bracket (2)†
- L Spacer (2)†
- M Long Bolts (8)†
- N Short Bolts (10)†
- O Nuts (18)†

\* These items are attached to the base for shipping purposes. Carefully remove from base and set aside.

‡ Only included in Twin XL and Cal King Split bases.

† This is an optional item and can be purchased



A



B \*



C



D



E

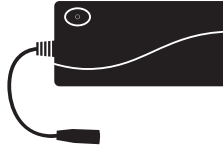

F †



G



H †



I

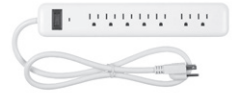

## HEADBOARD BRACKET COMPONENTS (Optional)

J †



K †

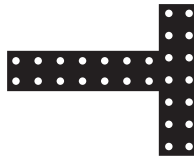

L †



M †

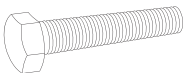

N †

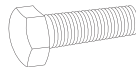

O †



# Base and Remote Overview

---

## BASE

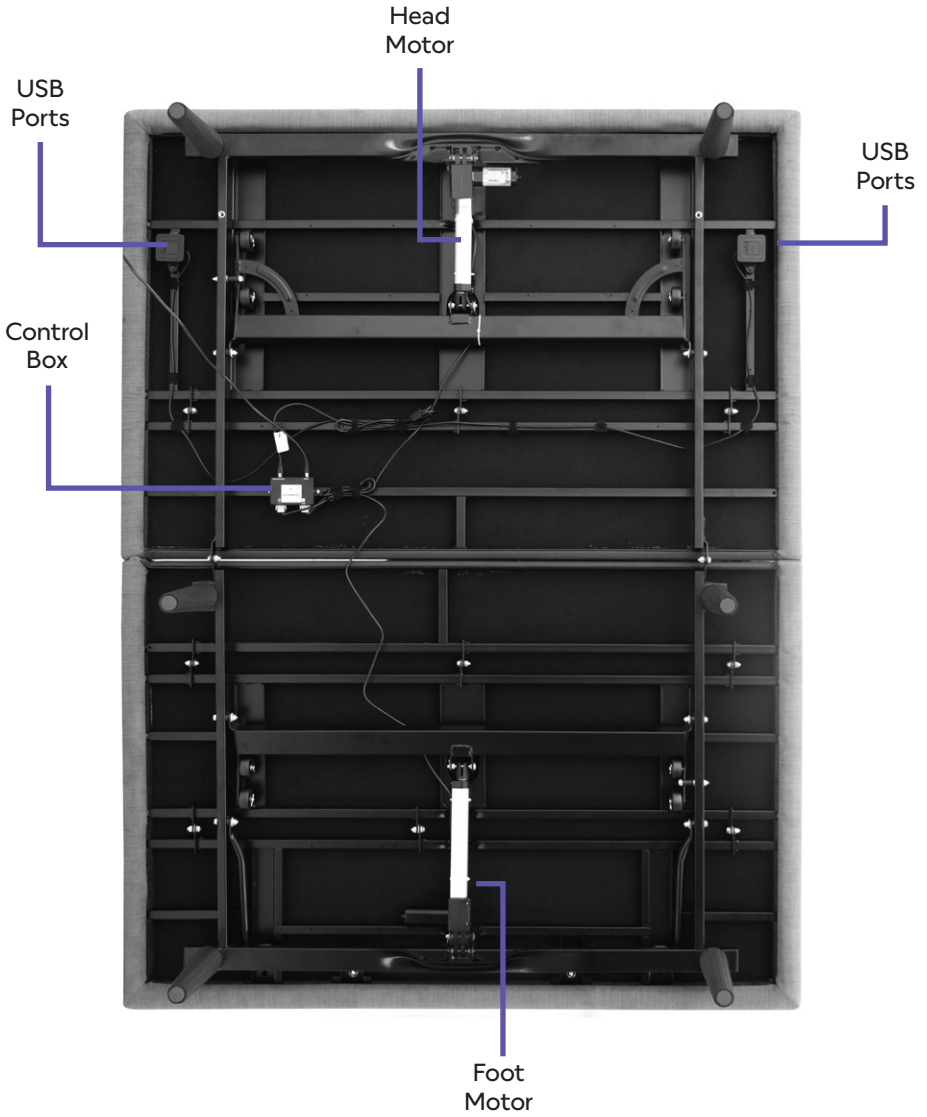

---

## REMOTE

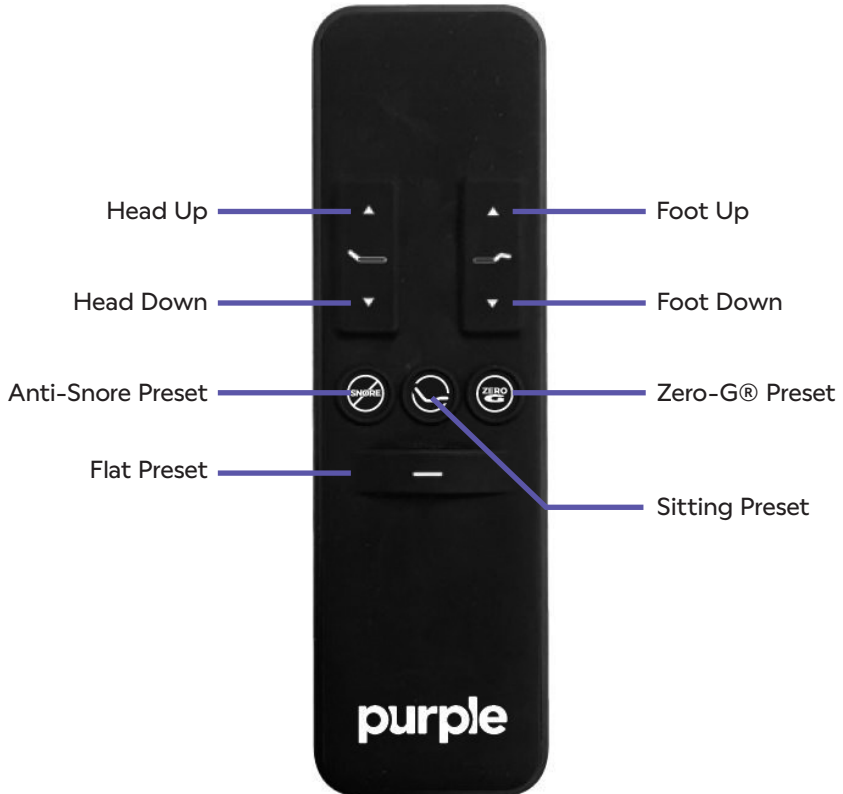

# Quick Reference Guide

---

## ELECTRONICS OVERVIEW



Remote



Emergency Battery Backup Strap

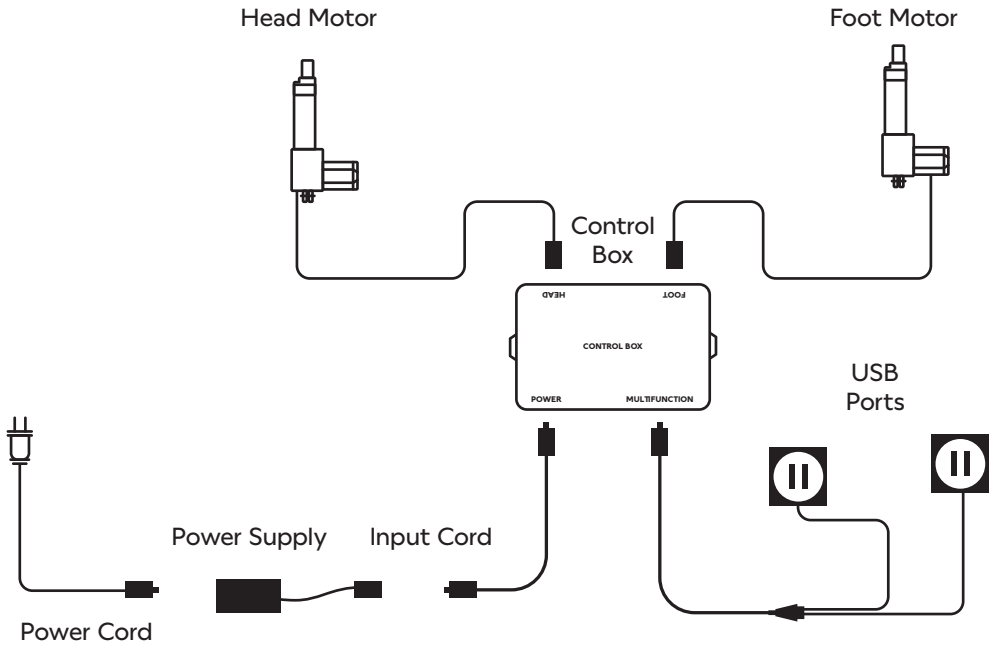

# Installation Guide

---

## INSTALLATION GUIDE

We've made the setting up of your Purple Ascent Adjustable Base as easy as possible so you can begin relaxing in less than 15 minutes! Do not attempt to set up the base by yourself. Always set up with the help of an additional, able-bodied person. Remove the binding straps and packing materials, making sure not to puncture the box with any sharp objects.

---

1

**Remove the bed base from the box and unfold it so that the bottom of the base is facing upwards.**

- When removing the bed base from the box, be cautious of pinch points and dropping hazards. Use two people to safely unfold the base.
- Remove the twist ties holding the retainer bar and set the retaining bar aside
- To install the legs, screw the bolt of the leg into the threaded holes. Tighten by hand. Repeat on all four corners and on each side in the middle.

**Do not over tighten.**





---

## INSTALLATION GUIDE

If installing a King, see instructions on pages 19-24.

---

2

### Flip the base & connect the cables.

- Uncoil the input cord (connected to control box's power port) and plug it into the power supply.
- Carefully flip the base over on to its legs. Important: Two people are required to move the bed base. Do not drag across the floor. Do not rest the frame on its side as excessive pressure may damage the legs.
- Insert the power cord into the power supply.
- Plug the power cord into a power outlet. A surge protector is recommended. Surge protector not included.

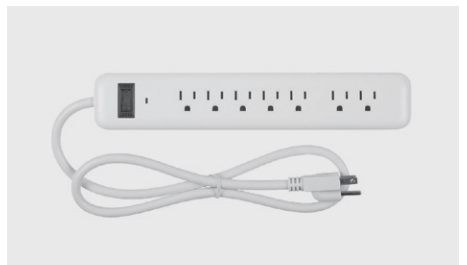

---

## INSTALLATION GUIDE

Purple has partnered with Ergomotion® on this amazing product.

For technical or warranty support please contact Ergomotion® at 1-888-550-3746.

---

3

### Install mattress retainer bar and test remote functions.

- Place each end of the mattress retainer bar into the inserts at the foot of the base and rotate the bar so that it rests on the edge of the base.
- Once plugged into power, and after putting AAA batteries into the remote, press the head up and down buttons as well as the foot up and down buttons to verify proper setup and function. Return the bed to a flat position before placing the mattress on top.
- If remote does not move the bed, make sure the bed is plugged in to power. If it still doesn't work, review the steps on page 27 to pair the remote.

**Setup is now complete!**

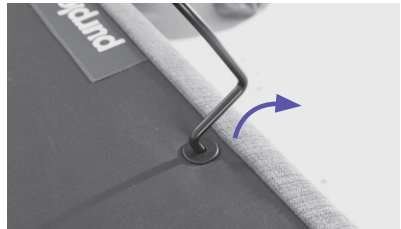
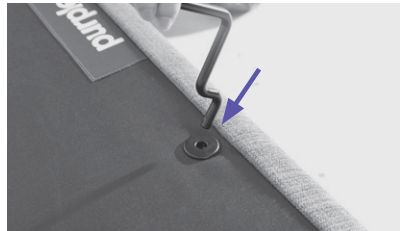

# King Installation Guide

---

## KING INSTALLATION GUIDE

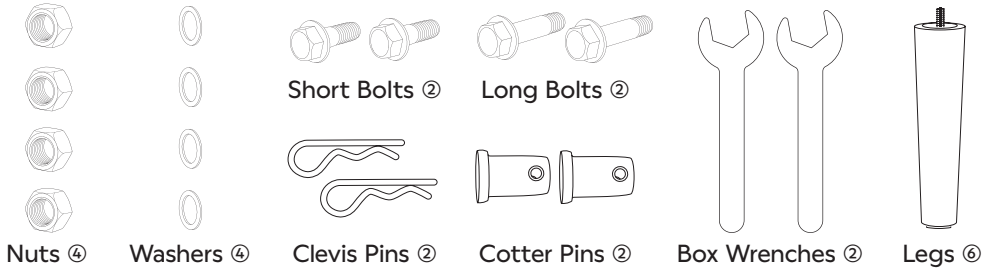

1

### Unfold the base

**Always use two people when setting up, moving, or flipping base.**

Unfold the base so that the bottom side is facing up.



---

## KING INSTALLATION GUIDE

Purple has partnered with Ergomotion® on this amazing product.

For technical or warranty support please contact Ergomotion® at 1-888-550-3746.

---

### 2

#### Secure hinge with short bolt

A Insert a short bolt through the first hole in the hinge of the frame.

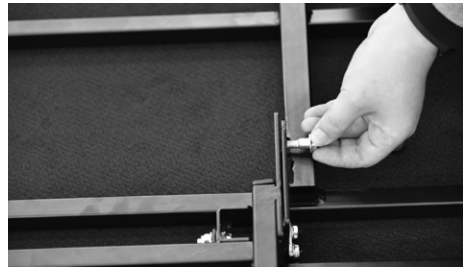

B Secure the end of the short bolt with a washer and a nut.

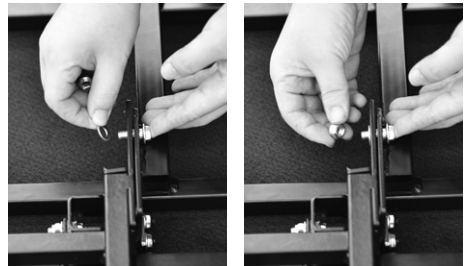

C Tighten the bolts with the box wrenches provided.

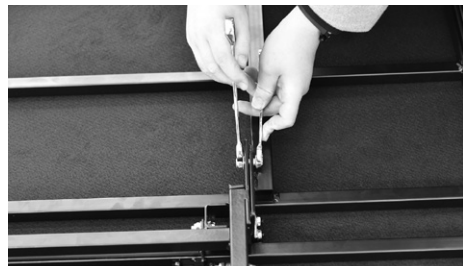

---

## KING INSTALLATION GUIDE

---

### 3

### Secure hinge with long bolt

A Insert a long bolt through the second hole in the middle of the hinge of the frame.

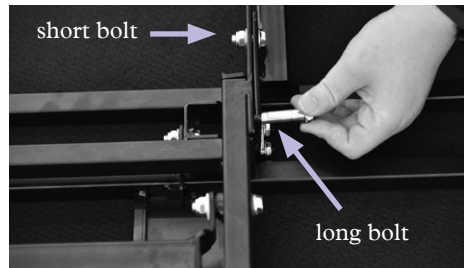

B Secure the end of the long bolt with a washer and a nut.

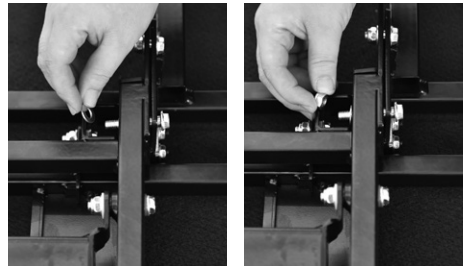

C Tighten the bolts with the box wrenches provided.

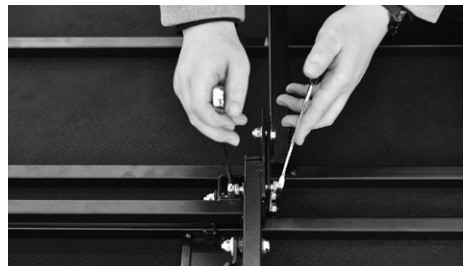

---

## KING INSTALLATION GUIDE

---

4

### Install pins

Insert a clevis pin through the hole of the connecting point located next to the leg inserts at the middle of the frame. Secure it with a cotter pin. Do this on each side of the frame.



---

## KING INSTALLATION GUIDE

Purple has partnered with Ergomotion® on this amazing product.

For technical or warranty support please contact Ergomotion® at 1-888-550-3746.

---

5

### Screw in the legs

Attach legs by screwing them into leg threads. Do this on all four corners and on each side in the middle. Tighten by hand. Do not over-tighten.

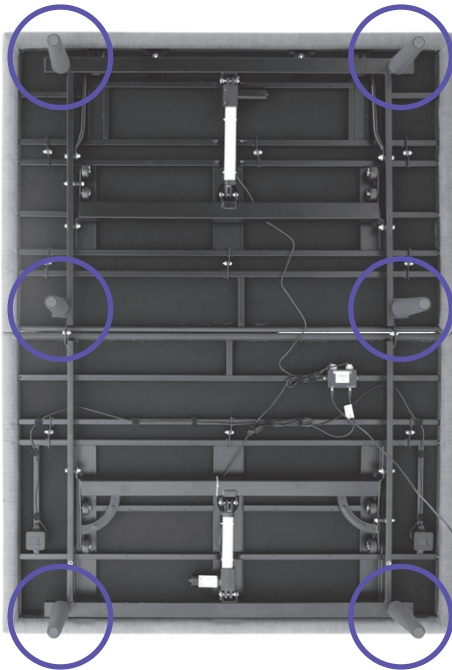

Please continue onto Step 2 on page 17 to complete installation.



# Remote Control

## REMOTE OVERVIEW



### A/AB/B SIDE CONTROL





If using a split King (two Twin XL's side-by-side), slide the toggle button on the back of the remote to select which side(s) of the base to control.

 The HEAD ▲ ▼ arrows lift and lower the head section of the base.

 The FOOT ▲ ▼ arrows lift and lower the foot section of the base.

 The ANTI-SNORE preset position\* will elevate the head section slightly and may help reduce snoring.

 The SITTING preset position\* will adjust the head and foot section to a comfortable position ideal for reading or watching television.

 The one-touch ZERO-G® preset position adjusts your legs to a higher level than your heart, helping to relieve pressure off the lower back and promote circulation.

 The one-touch FLAT preset position returns the base to a fully horizontal position.

### \*SAVE A NEW PRESET POSITION

- 1 Articulate the head and foot to your desired position.
- 2 Press and hold one of the Memory Preset buttons (ANTI-SNORE or SITTING) for 5 seconds. Position is now saved.
- 3 **NOTE:** To restore the preset buttons back to their original factory settings, hold FLAT and ZERO-G® simultaneously for at least 5 seconds. The original presets will be restored.

---

## PAIRING REMOTE CONTROL

The original remote that comes in the box is already paired to the adjustable base. No further action is required. In the event that the remote is not paired with the base, follow the steps below.

---

- 1 Unplug the power cord from your power outlet. Wait one minute, then plug it back in to your power outlet. Perform Step 2 within 10 seconds, while the control box light is flashing.
- 2 Remove the back cover on the remote. Press and hold the PAIR button on the back of the remote. The PAIR button will illuminate and start to flash. When the PAIR button stops flashing, the LED light on the control box will stop flashing. Release the PAIR button.
- 3 The remote is now paired. Test all remote functions. If the remote buttons do not impact the adjustable base movements, please repeat the process again or call Ergomotion® customer service: 1-888-550-3746.

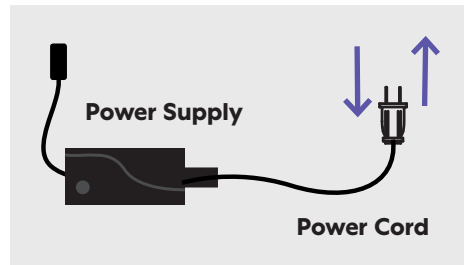

# Optional Adjustments

---

## CONNECTING STRAP (ONLY INCLUDED WITH TWIN XL)

Connecting straps are secured to the base frame upon delivery. Legs are required for the installation of the connecting straps. The straps are used for holding two Twin XL bases together for a Split King.

---

- 1 With the bases in their desired location, slightly loosen both legs to allow the strap to fit on the leg bolt, between the leg washer and frame.
- 2 Slide side (A) of the connecting strap onto leg bolt. Swing the strap and connect side (B) to the leg bolt. Secure the strap by shifting to the left.
- 3 Re-tighten legs. Do not overtighten. Use the remaining strap and repeat on other end of the base.

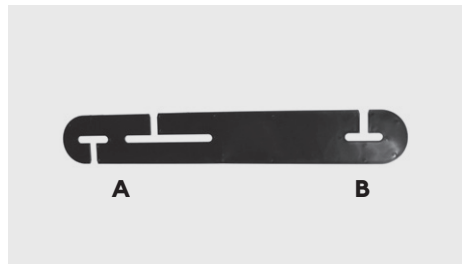

---

## SYNCING TWO BASES (OPTIONAL)

A Sync Cord is included with the Twin XL size base. Not available on Queen, Full or Full-Long size bases. The Sync Cord connects the two control boxes to a single remote for the synchronization of two bases. This process is most commonly used for syncing two connected Twin XL bases.

---

- 1 Unplug bases from power source.
- 2 Connect the Sync Cord to the Y-Cable on each control box.
- 3 Plug bases back into the power source.
- 4 Check to ensure all cords are securely attached. Both remotes will now operate both bases simultaneously. If both remotes are in the middle position of the A/B switch on the back of the remote, both beds will operate simultaneously.

### Sync Cord

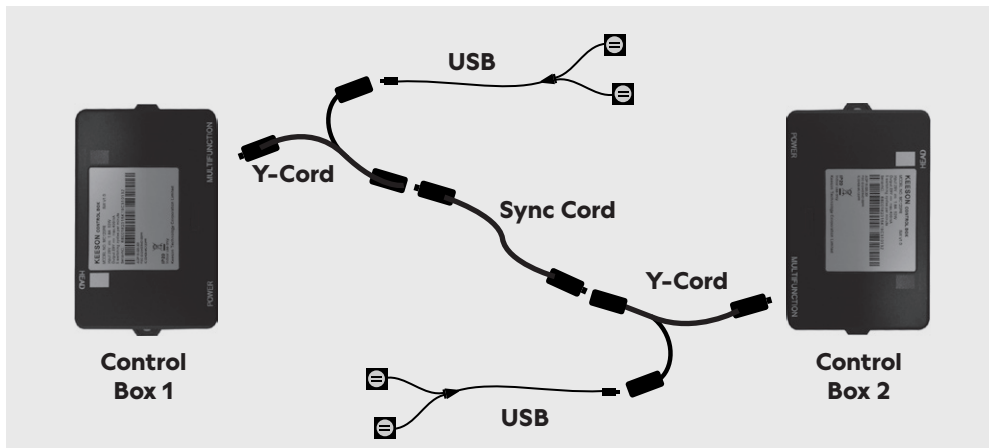
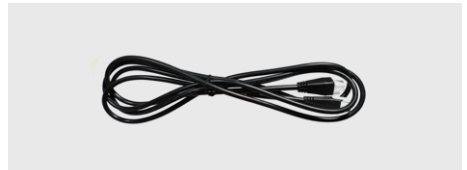

---

## HEADBOARD BRACKET INSTALLATION GUIDE (OPTIONAL)

Headboard brackets are not included. If interested in headboard brackets please visit [purple.com](http://purple.com) to order or call Purple at 1-888-848-0248.

A 9/16" (14 mm) & 1/2" (13 mm) socket and crescent wrench are necessary to complete installation.

---

1

- A Align the hole in the bracket to the brass sleeve into which the leg threads. Hold the bracket in place and screw the leg into the base until it is snug. **DO NOT OVERTIGHTEN.** Too much force may cause the leg to spin freely.



- B Align the tab with the hole in the frame (located towards the foot of the base) and use a short bolt and nut to secure the bracket. Make sure the bolt is tight.



---

## HEADBOARD BRACKET INSTALLATION GUIDE (OPTIONAL)

---

2

### Attach the plastic spacer and T-Bracket.

- A Measure the distance between the mounting holes on the headboard and install the spacer and attachment plate to accommodate the headboard.
- B To install the plastic spacer and attachment plate, you will need (2) long bolts and (2) nuts. Place the spacer and attachment plate in the desired location and slip the bolts through the holes with the head of the bolt facing outward. Position the bolts diagonally on the spacer. Use the 9/16" socket and wrench to tighten the bolts.



3

You may now connect your headboard to the attachment plates using the remaining short bolts and nuts to secure it to the brackets. The heads of the bolts will face outward. Use a 9/16" socket and 1/2" wrench to tighten the bolts.



---

## BATTERY BACKUP STRAP

For emergency use only, if the base is in an elevated position and the power goes out, you can use the battery backup strap to return the bed to a flat position. Batteries are not to be used for normal operation of the bed.

---

- 1 Disconnect the Power Supply from the input power cord.

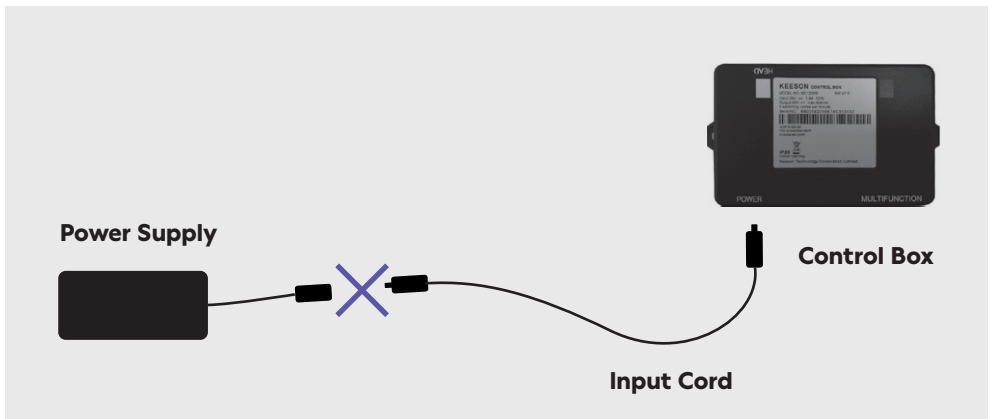

- 2 Connect the Battery Backup Strap to the (2) Alkaline 9 Volt batteries. Do not mix brand name Batteries.



---

## BATTERY BACKUP STRAP

Purple has partnered with Ergomotion® on this amazing product.

For technical or warranty support please contact Ergomotion® at 1-888-550-3746.

---

- 3 Connect the end of the Battery Backup Strap to the input cord that is attached to the control box.

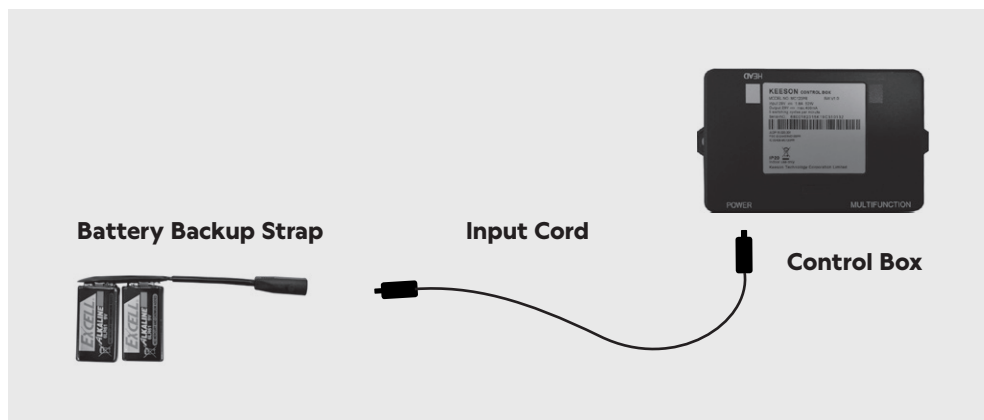

- 4 Use the remote to return the base to a flat position.

NOTE: Detach the Battery Backup Strap and reconnect the power supply after the emergency is over, as the system will continue to draw power from the batteries even if not in use.

---

## TROUBLESHOOTING

If one or more functions on the bed base have stopped operating:

- 
- Check under the bed base to verify that the wired connections are secure and that there are no cords or bedding obstructing the movement of the base.
  - Check to ensure the LED light is illuminated on the power supply. If there is no light, verify that the input and power cords are properly connected.
  - Unplug the base for 10 minutes to reset the electronic components.
  - Plug bed base into a different electrical outlet, or test current outlet with another working appliance (a grounded, electrical surge protector is recommended).

If issue is not resolved by following the instructions above, call Ergomotion® technical or warranty support at: 1-888-550-3746

**Ergomotion® Customer Service: US 1-888-550-3746**

---

## NOTES

---

---

---

---

---

---

---

---

---

---

---

---

---

---

---

---

---

---

---

---

---

---

---

---

## NOTES

---

---

---

---

---

---

---

---

---

---

---

---

---

---

---

---

---

---

---

---

---

---

---

---

## PURPLE 10 YEAR LIMITED WARRANTY FULFILLED THROUGH ERGOMOTION®

Register your warranty online at:

<https://warranty.ergomotion.com/warranty>

Please prepare a digital copy of your proof of purchase (invoice or sales receipt) when registering online.

---

### **2-Year Hassle Free Warranty**

Your adjustable base is warranted by the manufacturer against defects in materials or workmanship for a period of two years from the date of purchase to the original Purchaser. During such time, the manufacturer will repair or replace, at no cost to the original Purchaser, any warranted part(s)\* found to be defective by the manufacturer, in its sole discretion. This includes all pre-authorized labor and transportation costs incurred with the repair or replacement of any part found to be defective.

### **5-Year Warranty on Parts**

During year 3 through 5 from the original purchase date, the manufacturer will replace any part on the adjustable base found to be defective by the manufacturer, to the original Purchaser. The manufacturer's liability is limited to the replacement of the defective electrical/mechanical part(s)\* ONLY with the Purchaser responsible for all service, installation, and transportation cost of said part(s).

### **10-Year Limited Warranty**

Notwithstanding the above, the manufacturer extends a 10-year warranty on mechanical base parts found to be defective on a limited basis as defined herein. Specifically, the manufacturer warrants that for a full 10 years from the commencement date of this warranty, any defect in the workmanship or the materials used shall be covered. For purposes of this 10-year warranty, it specifically excludes the cover, shroud, platform, legs, actuator lift motors, massage motors, control box, remote controls, power supply, and all power supply cords. The purchaser shall pay 1/5 of the current MSRP of the replacement

part, or the entire adjustable base if deemed irreparable at the sole discretion of the manufacturer, multiplied by the number of years after the fifth year from the original purchase date. The manufacturer's liability shall be limited to the replacement of the defective part(s) ONLY with the purchaser responsible for all service, installation and freight costs for said part. This warranty does not apply to floor models.

### **2-Year Floor Model Warranty**

Your adjustable base floor model is warranted against defects in the electronics for a period of two years from the date of purchase to the original Purchaser. During the first two years the manufacturer will replace at no cost to the original Purchaser, any defective electronic part(s). The manufacturer's liability is limited to the replacement for the defective electronic part(s) ONLY with the Purchaser responsible for all service, installation and transportation cost of said part(s).

### **ADDITIONAL TERMS & CONDITIONS**

This warranty does not include reimbursement/ replacement for inconvenience, removal, part(s) installation, bed set up, loss of use, normal wear and tear, shipping or any other costs or expenses not expressly covered in this warranty. In addition, this warranty shall be void in the following circumstances:

- A. Damage resulting from misuse or abuse caused by the Purchaser or any third party.
- B. Damage caused by repairs or parts replacement by an unauthorized person.

C. Damage caused if the adjustable base has been mishandled (including during shipping), subject to physical abuse or an improper power supply, or by failing to adhere to the Owner's Manual and this warranty.

D. Damaged mattresses, foundation cover(s), fabric(s), bedding cables, electrical cords or accessories supplied by dealers or any third party. Contact your dealer for warranty information on these items.

E. Modification of the adjustable base without prior written consent by the manufacturer.

F. Costs for unauthorized service calls for the purpose of educating the consumer about the adjustable base or locating proper functioning power outlets.

G. Damage if the recommended weight restrictions are exceeded.

H. Damage if used in any environment or a commercial setting which was not intended.

I. This warranty requires notice to be given to Ergomotion® of any claim for repairs or replacement parts.

J. Damage to foam shroud by improper handling or misuse.

\*Parts include the following:

- a) Head/Foot Actuator
- b) Massage Motors and Housing
- c) Control Box
- d) Remote Control
- e) Power Cord, Power Supply, and Input Cord
- f) Mounting Brackets
- g) Support Struts

OTHER THAN AS EXPRESSLY SET OUT HEREIN, AND TO THE EXTENT PERMITTED BY APPLICABLE LAW, THIS WARRANTY IS EXCLUSIVE AND IN LIEU OF ALL OTHER ORAL OR WRITTEN WARRANTIES, REPRESENTATIONS, CONDITIONS OR PROMISES, WHETHER EXPRESS OR IMPLIED, AND WHETHER ARISING BY LAW, STATUTE, COURSE OF DEALING OR USAGE OF TRADE, INCLUDING, BUT NOT LIMITED TO, IMPLIED WARRANTIES AND CONDITIONS OF MERCHANTABILITY, QUALITY, DURABILITY AND/ OR FITNESS FOR A PARTICULAR PURPOSE. TO THE EXTENT

PERMITTED BY APPLICABLE LAWS, ANY IMPLIED WARRANTIES (IF APPLICABLE) ARE LIMITED IN DURATION TO THE DURATION OF THIS WARRANTY. TO THE EXTENT PERMITTED BY APPLICABLE LAW, IN NO EVENT SHALL THE MANUFACTURER BE LIABLE FOR ANY SPECIAL, INCIDENTAL, PUNITIVE, EXEMPLARY, CONSEQUENTIAL, LIQUIDATED OR SIMILAR DAMAGES, WHETHER OR NOT FORESEEABLE.

Note: The exclusion directly above is inapplicable to consumers residing in Québec.

To the extent permitted by law, this warranty is not transferable and will automatically terminate if the original Purchaser sells or otherwise disposes of the adjustable base.

This warranty gives the Purchaser specific legal rights. Other rights, which vary from jurisdiction to jurisdiction, may exist. In addition, some jurisdictions do not allow (i) the exclusion of certain warranties, (ii) limitations on how long an implied warranty lasts and/or (iii) the exclusion or limitation of certain types of costs and/or damages, so the above limitations may not apply.

This warranty is only valid in The United States, Canada and Puerto Rico. For all other jurisdictions, this Limited Product Warranty is valid only in the jurisdictions where the Products are sold by an Ergomotion® authorized reseller or agent and is valid to the extent permitted by the applicable laws of such jurisdictions.

### **Weight Limits**

This product is not rated to support weights exceeding 650 pounds (295 kg). This product is not rated to support weights in excess of 650 pounds (295 kg) inclusive of the mattress and bedding. The base will structurally support this weight, provided it is evenly distributed across the bed base. The adjustable base is not designed to support or lift this amount in the head or foot sections alone. Exceeding this weight restriction could damage the bed and/or cause injury and will void the warranty.

**For warranty claims, call Customer Service  
US 1-888-550-3746**

**[info@ergomotion.com](mailto:info@ergomotion.com)  
[www.ergomotion.com](http://www.ergomotion.com)**

**TECHNICAL AND WARRANTY SUPPORT:**

**©2020 PURPLE INNOVATION, LLC.**

**PURPLE HAS PARTNERED WITH ERGOMOTION®  
TO PROVIDE SUPPORT FOR THE PURPLE  
ASCENT ADJUSTABLE BASE**

Phone 1.844.534.3676

Fax 1.805.979.9399

Email [info@ergomotion.com](mailto:info@ergomotion.com)

Web [www.ergomotion.com](http://www.ergomotion.com)



The Purple® Ascent Adjustable Base™